

Early History & a 50 Year Perspective on Magnetic Disk Storage

The Genesis of the Current Revolution in Information Storage

Albert S Hoagland



2/28/05

Magnetic Disk Heritage Center

ASH

One Perspective on History

- A poll (academics, professionals as well as others in the general population) taken at the end of the last millennium (2000) published a summary of the replies to the following request:
- **Rank order the individuals whom you consider to have had the greatest influence on the course of history during the last Millennium. (1 through 100)**

BIOGRAPHY® OF THE MILLENNIUM
Names the Top 100
Most Influential People of the Past 1,000 Years

- Gutenberg tops the list!
- With BIOGRAPHY anchor Harry Smith

- 1 Gutenberg, Johann 2 Newton, Isaac 3 Luther, Martin 4 Darwin, Charles 5 Shakespeare, William 6 Columbus, Christopher 7 Marx, Karl 8 Einstein, Albert 9 Copernicus, Nicolaus 10 Galileo Galilei 11 Da Vinci, Leonardo 12 Freud, Sigmund 13 Pasteur, Louis 14 Edison, Thomas 15 Jefferson, Thomas 16 Hitler, Adolf 17 Gandhi, Mahatma 18 Locke, John

- web site: www.biography.com/features/millennium

OUTLINE

- Overview of the information storage timeline
 - The 1950's: The beginning of magnetic disk data storage
 - Follow-on design and technology activities initiated in 1950's
- =====
- A 40 year perspective of the evolution of magnetic disk storage
 - 1960 to 1980 (period of the 14 inch disk)
 - 1980 to 2000 (the PC arrives: disk drive industry arises, density advances precipitate and accelerate form factor reductions and new applications)
 - Beginning of the 21st century, what are the challenges and opportunities faced?
 - The Magnetic Disk Heritage Center
 - Mission and associated initiatives
 - The RAMAC restoration Project

Information Storage Defined

- **Information: Content intended to be widely disseminated and shared**
 - **Includes all types of information including voice, images, symbols, text, video and other time varying patterns, etc.**
- **Storage: Media must be non-volatile and readily accessible for adding, retrieving and sharing information**

Beginning of technology changes - Moveable-Type Printing Press

- **Preceded by oral and then written communications**
- **Radically changed society by allowing the wide dissemination of information and knowledge**
 - Introduced in 15th Century by J Gutenberg, Mainz, Germany
 - Content (printed text, symbols and engravings)
 - Stored information is human readable
 - Medium: paper
 - Information transfer: by physical transport
 - Libraries: repositories for public access

As to the Evolution of “Business Data” Processing”

- In-line: direct barter systems. Operations were immediate.
- As became more formalized transactions were posted to their final record forms (paper) in the sequence they occurred. Distribution was made manually directly to the appropriate ledgers.
- In time manual in-line processes could not keep up with the demands for relatively current data in an easy digestible form.
- Mechanization was first approached by “batch” processing, that is with simple devices that that performed many simple repetitive type operations. Thus, file information was handled in fixed pre determined order. What was missing was a random access memory so that the input data could be processed in the to sequence in which data was received.

Punched Card

- In **19th century** the need for record keeping and computing were growing beyond manually maintained ledgers.
- H. Hollerith took the punched card idea of the Jacquard loom and developed equipment for sorting, collating and tabulating census data from key-punched cards
 - “Binary coding” made the **machine processing** of large amounts of data possible.
 - Content: alphanumeric data
 - Data was processed in batches due to the sequential character of data access as well as the limited applications of data processing
 - IBM led in making punched cards and batch processing the basis of business data processing in first half of 20th century

Two Other Emerging Storage Technologies in 19th Century

- Photographic film for recording images emerged and became popular in late **19th century**
 - Film roll and box camera (G. Eastman)
- =====
- In **1898**, magnetic recording) was invented by Vlademar Poulsen for the analog recording and playback of voice
 - During the first half of the 20th century efforts focused on the analog recording of speech and music on magnetic wire and tape. Like paper, card, and film media, magnetic media was nonvolatile but *in addition* also reusable.

100th Anniversary at SCU

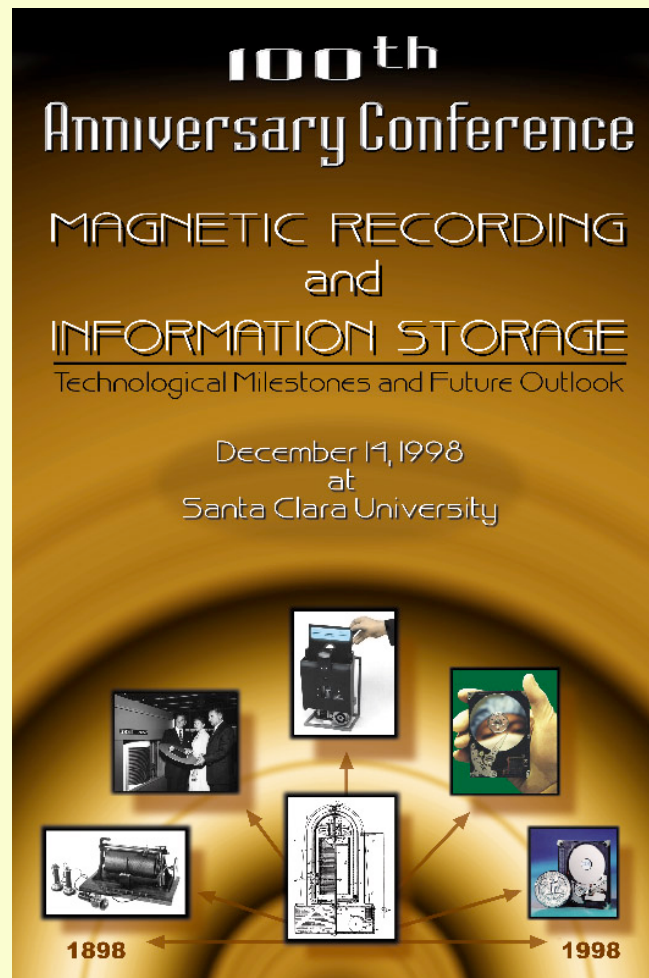

2/28/05

Magnetic Disk Heritage Center

ASH

Status of Data Storage Today

- Magnetic disk storage is rapidly taking over the primary role of providing the storage, retrieval and the world-wide distribution of information and knowledge in our society via the Internet.
 - Initially revolutionized information processing industry by providing on-line real-time transaction processing
 - Able to store all “types” of information
 - Already has led to the demise of punched cards and is rapidly replacing photographic film as a storage medium.

The Start of a Paradigm Shift in Data Storage (Late 1940's and early 1950's)

- **Primary Cause:**
- **Advent of the electronic computer, the ENIAC**
 - Vacuum tube memory
 - Paper tape and punched card I/O
- **Digital non-contact magnetic recording**
 - High head to medium speeds with no problems from wear
- **Semiconductor technology**
 - Large scale integration
- **Data communications and packet switching**
 - DARPA

UCB Magnetic Drum Memory, a low cost memory design for CALDIC, (1948-1952)

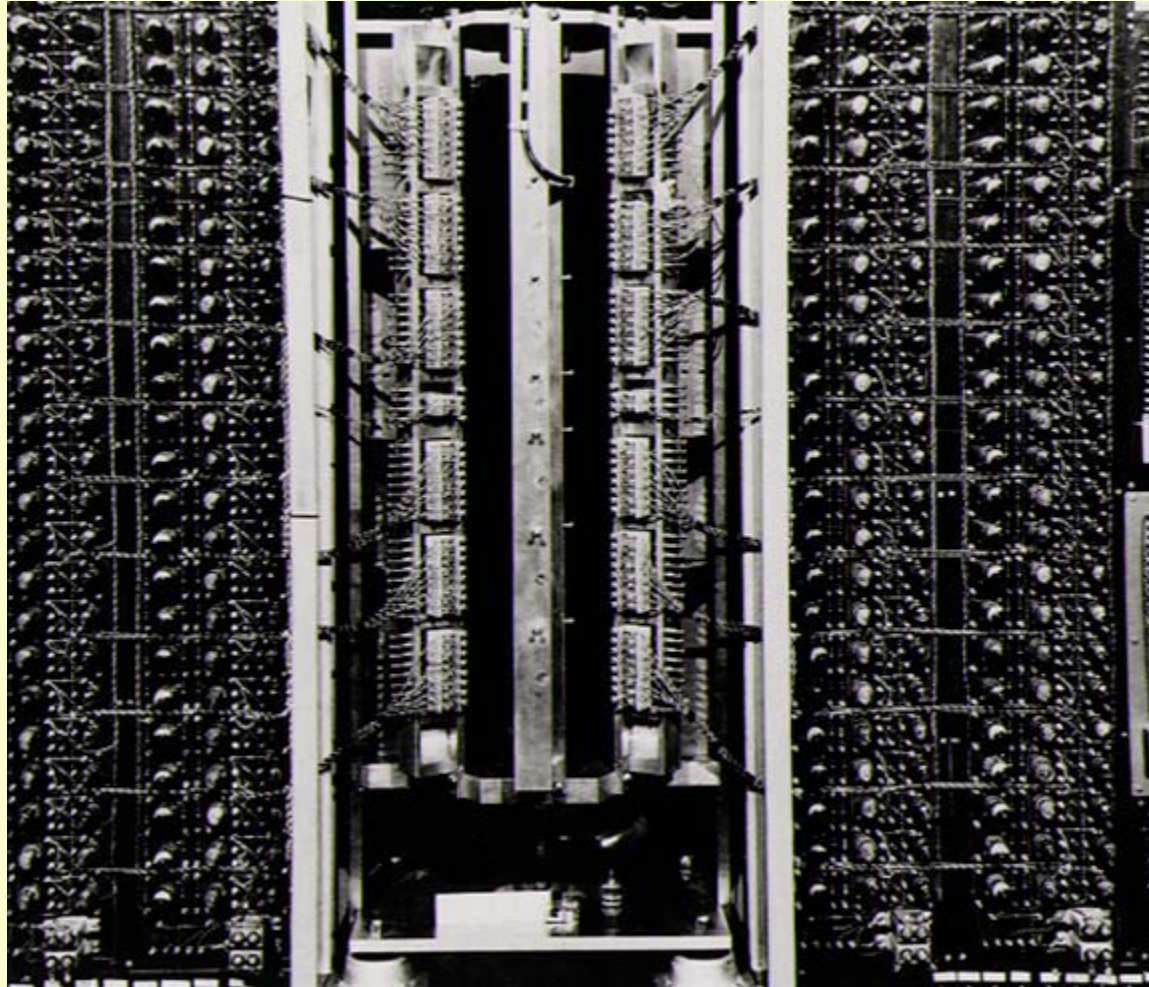

2/28/05

Magnetic Disk Heritage Center

ASH

The Origins of Magnetic Disk Storage in 1950's

- Growing interest and desire for on-line system storage that would allow random access to any record in a low cost data storage device of high capacity to support transaction processing for applications like accounting and control.
- Computer systems I/O were then based on punched cards, paper and then magnetic tape all subjecting applications to the limitations inherent with batch processing procedures.

“Random Access” Storage Characteristics Felt Required

- For *very high capacity*: Large recording medium surface area within a reasonable volume (led to disk stack)
- For *low cost per byte*: Read/write head positioning (each head servicing many tracks) (2 heads for 50 disks on RAMAC)
- For *short access time*: An access mechanism that can locate and read or write any record in less than a second
- For *high data rate*: high head-medium relative velocity (1200 rpm)

RANDOM ACCESS METHOD OF ACCOUNTING AND CONTROL (RAMAC)

Original targets and those implemented

Features	Proposed targets set <u>2/53</u> Served as basis for choice of disk stack	RAMAC (<u>announced 9/56</u>)
Disk diameter	16 inches	24 inches
Number of disks	50	50
Bits per inch	200	100
Tracks per inch	20	20
Capacity	4 MB	5 MB
Rpm	960	1200
Data rates	2 (inner and outer band)	1 (constant data rate)
Maximum seek time	Less than one second	0.7 seconds

The Early Years

Magnetic Disk Time Line

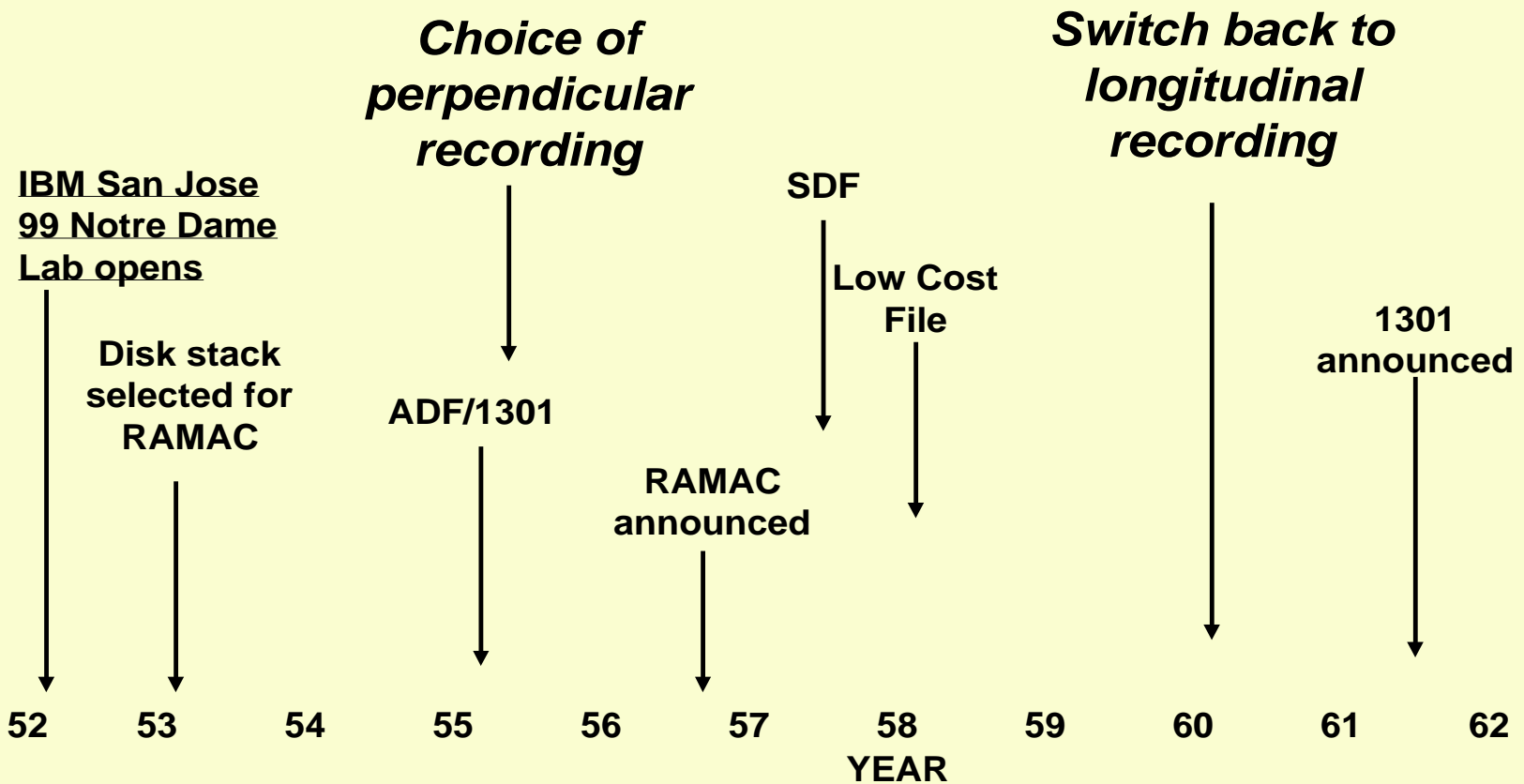

2/28/05

Magnetic Disk Heritage Center

ASH

Key Decision #1

Proof of Concept of Magnetic Disk Stack



2/28/05

Magnetic Disk Heritage Center

ASH

Key Decision # 2

Head/medium spacing control by using pressurized
Air Bearing Magnetic Head

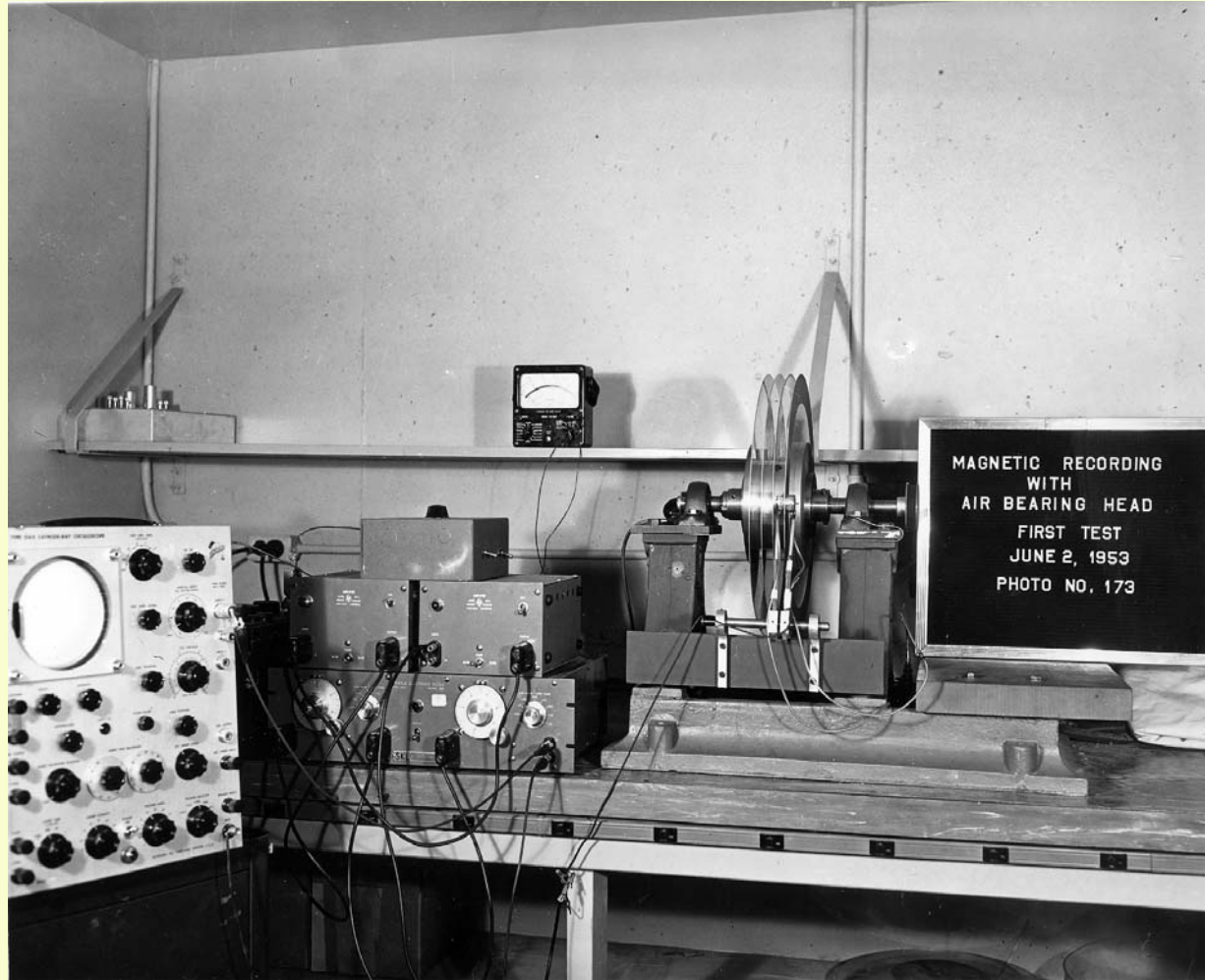

2/28/05

Magnetic Disk Heritage Center

ASH

Miniaturized Magnetic Head Design ---- (needed for 0.4 inch disk stack spacing and 1 mil head/disk spacing)

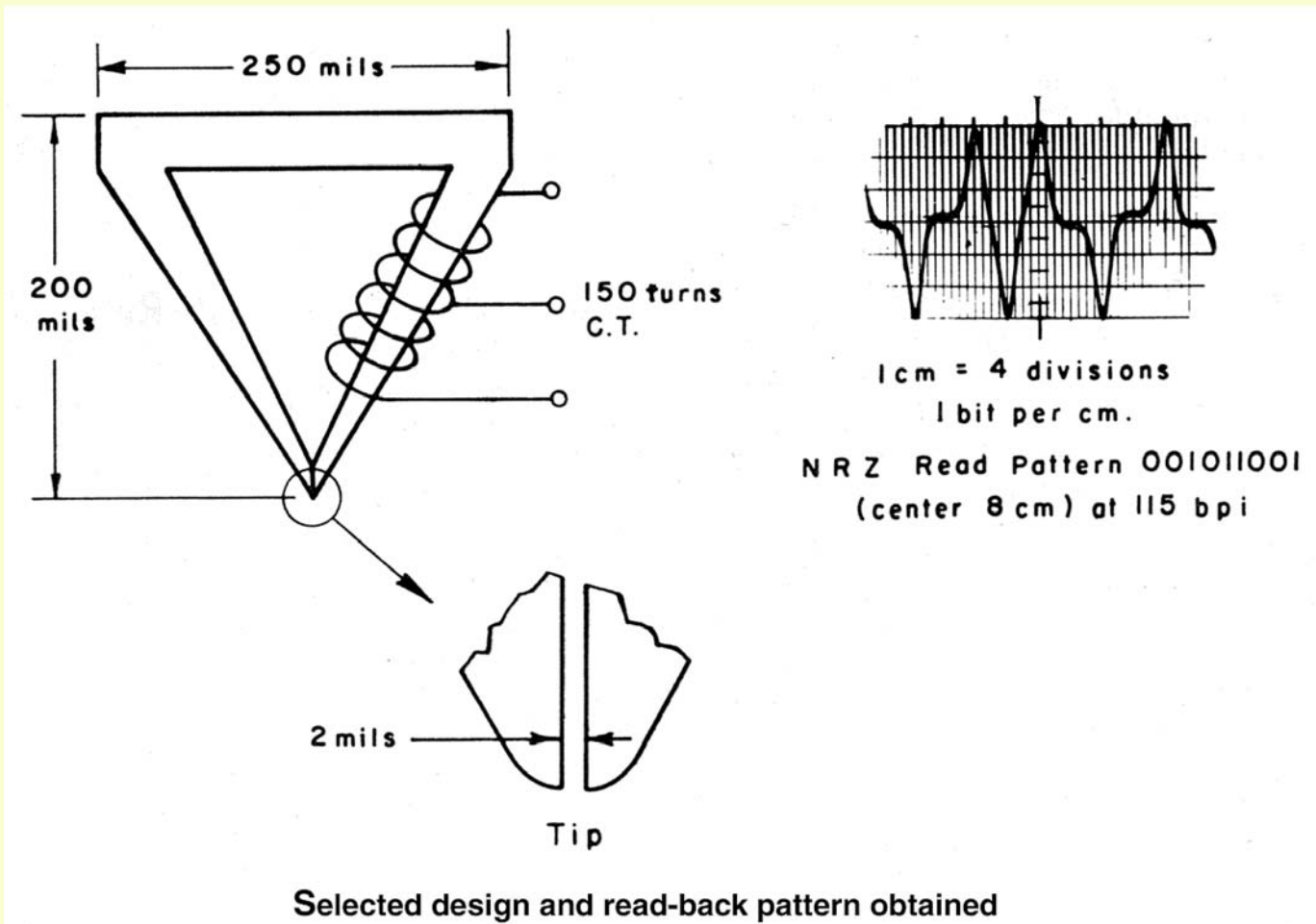

The Random-Access Memory Accounting Machine

I. System Organization of the IBM 305

**M. L. Lesser
J. W. Haanstra**

Abstract: The design features of a new automatic data processing machine for business applications, utilizing a random-access memory system, are described. Unlike the usual "batch" method of machine-processing business transactions, the technique used permits transfer of information between any two points in the system and allows multi-choice decisions according to the current status of the information. The "in-line" operational concept is discussed in detail and the data transfer routes and processing controls are shown. Employing punched-card input and printed-record output, the IBM 305 accounting machine is designed to handle 10,000 line-transactions per day.

RAMAC Access Mechanism

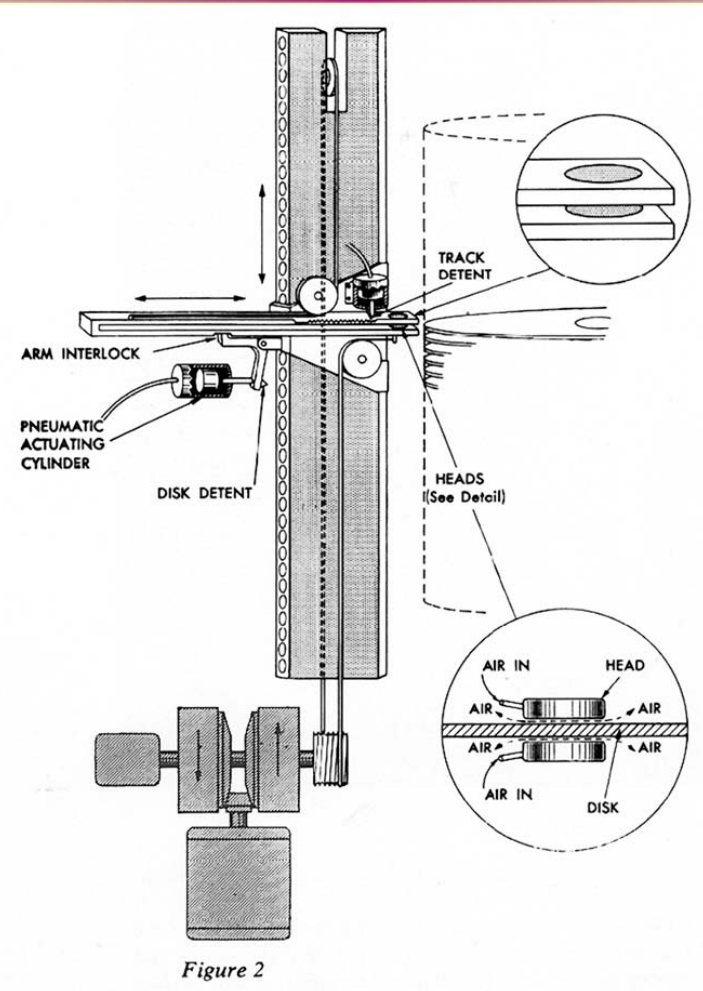

RAMAC Access Positioning Method

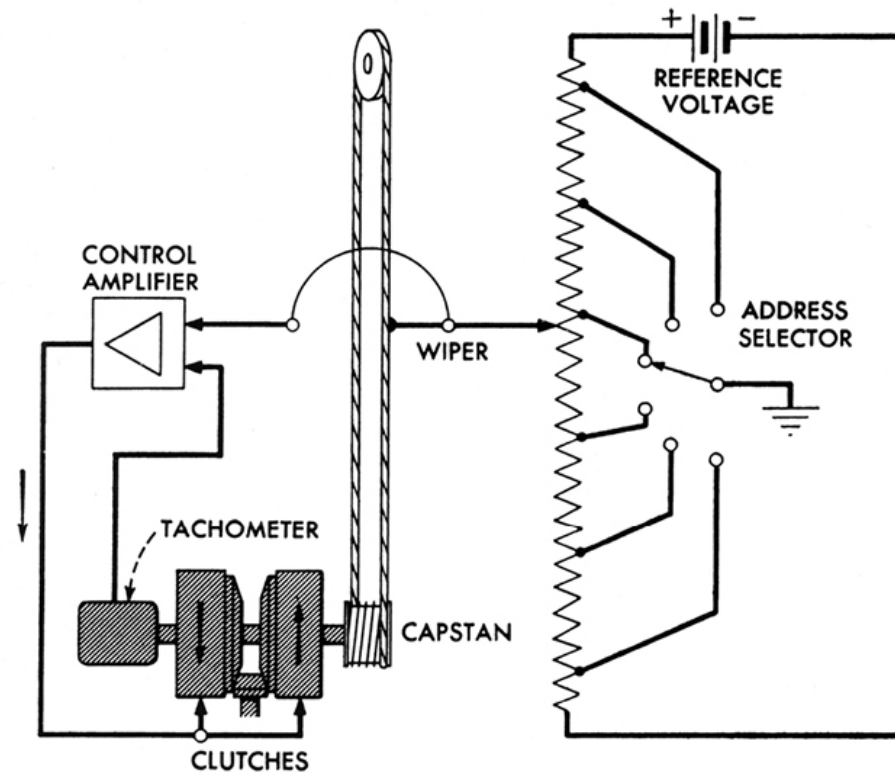
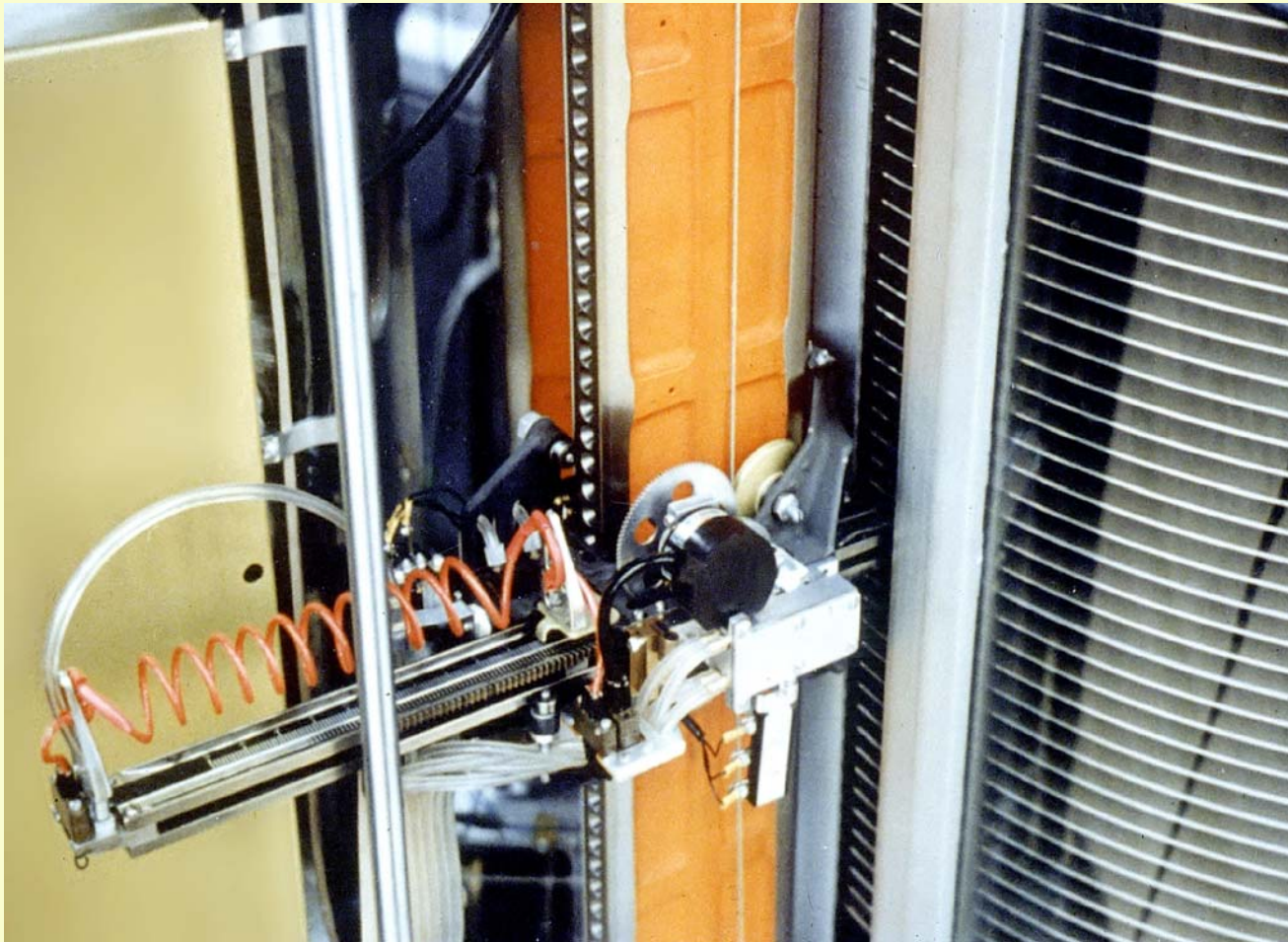

Figure 3
Functional schematic for either horizontal or vertical positioning by access mechanism.

IBM RAMAC 350 disk drive



2/28/05

Magnetic Disk Heritage Center

ASH

Top View of Disk Stack, Showing Magnetic Heads Used for Rotational Positioning



2/28/05

Magnetic Disk Heritage Center

ASH

Project Goal

IBM 305 RAMAC SYSTEM



2/28/05

Magnetic Disk Heritage Center

ASH

IBM 305A RAMAC SYSTEM

Santa Clara University

([click here for more information](#))



2/28/05

Magnetic Disk Heritage Center

ASH

Innovations initiated in 1950's (in downtown San Jose)

- **IBM 305 System** offering transaction processing based on Magnetic Disk Storage
- **RAMAC 350** disk file
 - Disk stack, pressurized air controlling spacing between head & disk, head positioning, miniaturized magnetic head, self clocking
- **ADF (1301)**
 - Flying head per surface, access time involving only track seeks
- **SDF** (prototype)
 - Head positioning by servoing on disk, providing path to major increases track density. (First incorporated in the IBM 3330 1971.) The RAMAC, IBM 1301 and 1311 were all open loop.
- **IBM 1311**
 - Low cost disk drive
 - Removable 14 inch disk pack (initially only 2 MB)

The RAMAC & Next Generation Follow-on Product Specifications Comparison

Features	<u>RAMAC</u> (on-line direct access storage)	Next Generation) <u>ADF</u> (<i>real time</i> on-line direct access storage)
Capacity	5 MB	50 MB
Maximum access time	1 second	Approx 0.1 seconds
Bits per inch	100	500
Tracks per inch	20	50
Spacing	1000 micro inches	250 micro inches
Rpm	1200	1800
Data rate (Kbytes/sec)	8.8	68
Head/arm assembly	Head pair	Comb (head/surface)
Actuator	Electro-mechanical	Hydraulic

Design Comparisons

Feature	RAMAC	ADF (Next Generation)
Head/medium interface Recording mode Magnetic head Magnetic disk Head positioning	Pressurized Air Head Longitudinal Ring Aluminum, magnetic paint Electro-mechanical	Flying Head <i>Perpendicular</i> <i>Probe</i> <i>Steel, oxidized</i> Hydraulic
Degree of innovation	High No precursor	High No precursor
Overall Technical Risk Commonality	High Disk stack	Very High Disk stack
Commercial Risk	Low Entrepreneurial venture Outcome unanticipated	Very High Key to IBM Computer strategy

Perpendicular Recording Probe Head Original Approach in 1301 Development

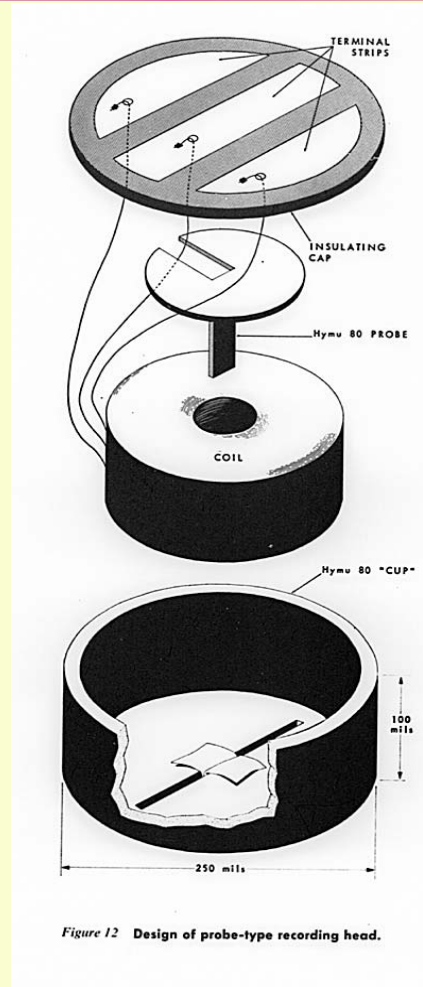

**IBM 1301(Commercial Version of ADF)
featured a “flying head” per surface
(used longitudinal recording with “ring” heads)**

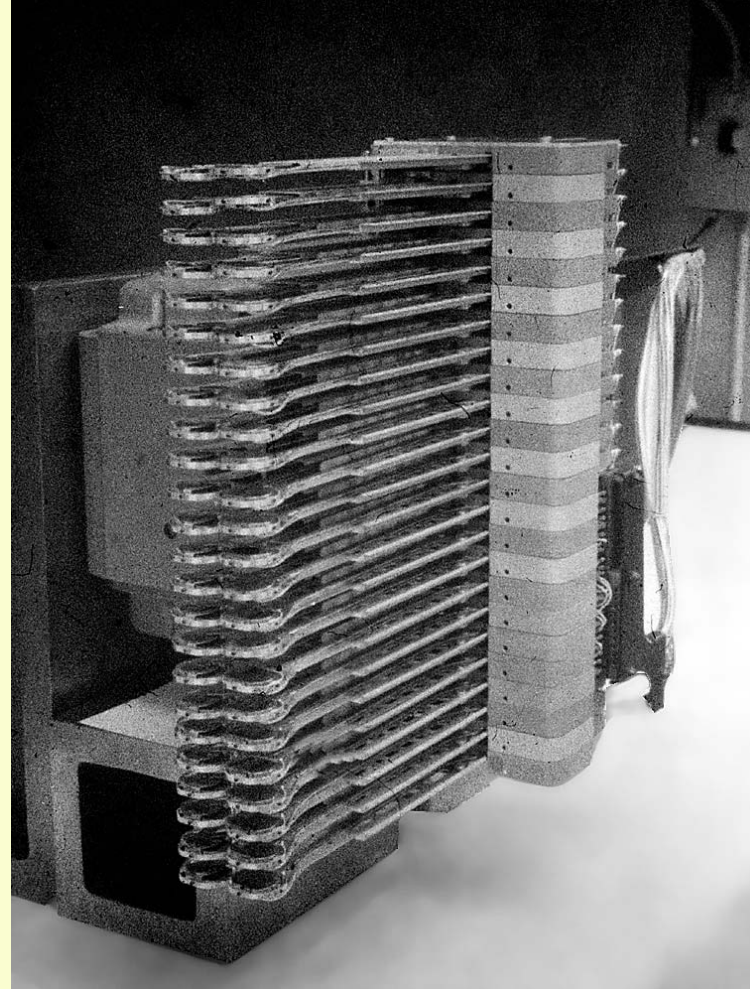

2/28/05

Magnetic Disk Heritage Center

ASH

A Few Consequences from the ADF Experience

- ❑ **Slowed rate of technical innovation. Magnetic disk technology is highly multidisciplinary and this experience led to practice of introducing only one new technology in each succeeding product generation**
- ❑ **Brought about the start of basic research on magnetic disk storage. The innovative approach taken for the RAMAC project, was no longer appropriate for committed products with the increasingly sophisticated levels of technology required.**
- ❑ **IBM disk drive leadership was maintained in spite of pursuing perpendicular recording for 5 years and then switching back to longitudinal recording**
 - ❑ **One irony: Today, perpendicular recording is viewed as the great hope for the future.**
 - ❑ **A lesson learned: a disk drive could be the most interdisciplinary**

Perpendicular Recording

The First Product Design Experience

- ❑ **For five years (1955 – 1960) the mainstream IBM disk drive technology was based on perpendicular recording.**
- ❑ **Perpendicular heads and oxidized steel disks chosen premised on projected major cost advantages with no existing experience to support these choices.**
- ❑ **One fundamental problem: Unable to properly evaluate these unproven recording components due to the concurrent inadequate understanding of flying head technology and design.**
- ❑ **Fortuitous that RAMAC longitudinal recording technology was still being pursued for RAMAC product upgrades**

Single Disk File (SDF) Project (1957-1959)

First disk drive design using a track-following servo system,
([click here for published paper on work](#))

Goal:

Replace tape
cartridge
with
removable
disk

Storage density:
100 times that of
RAMAC

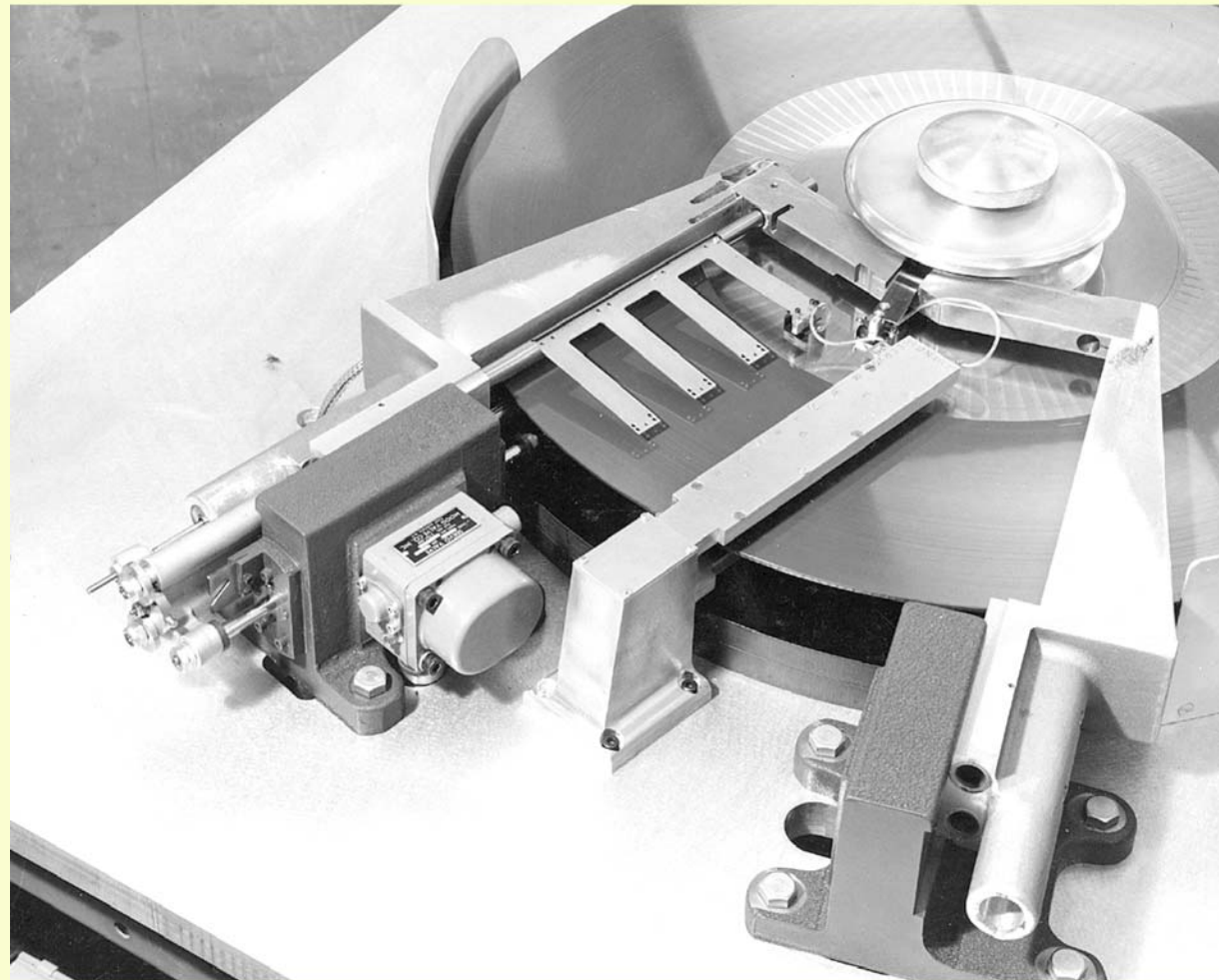

2/28/05

Magnetic Disk Heritage Center

ASH

Disk Pack (Design approach initiated in 1959)
IBM 1311 Disk Pack (announced in 1963) shown below

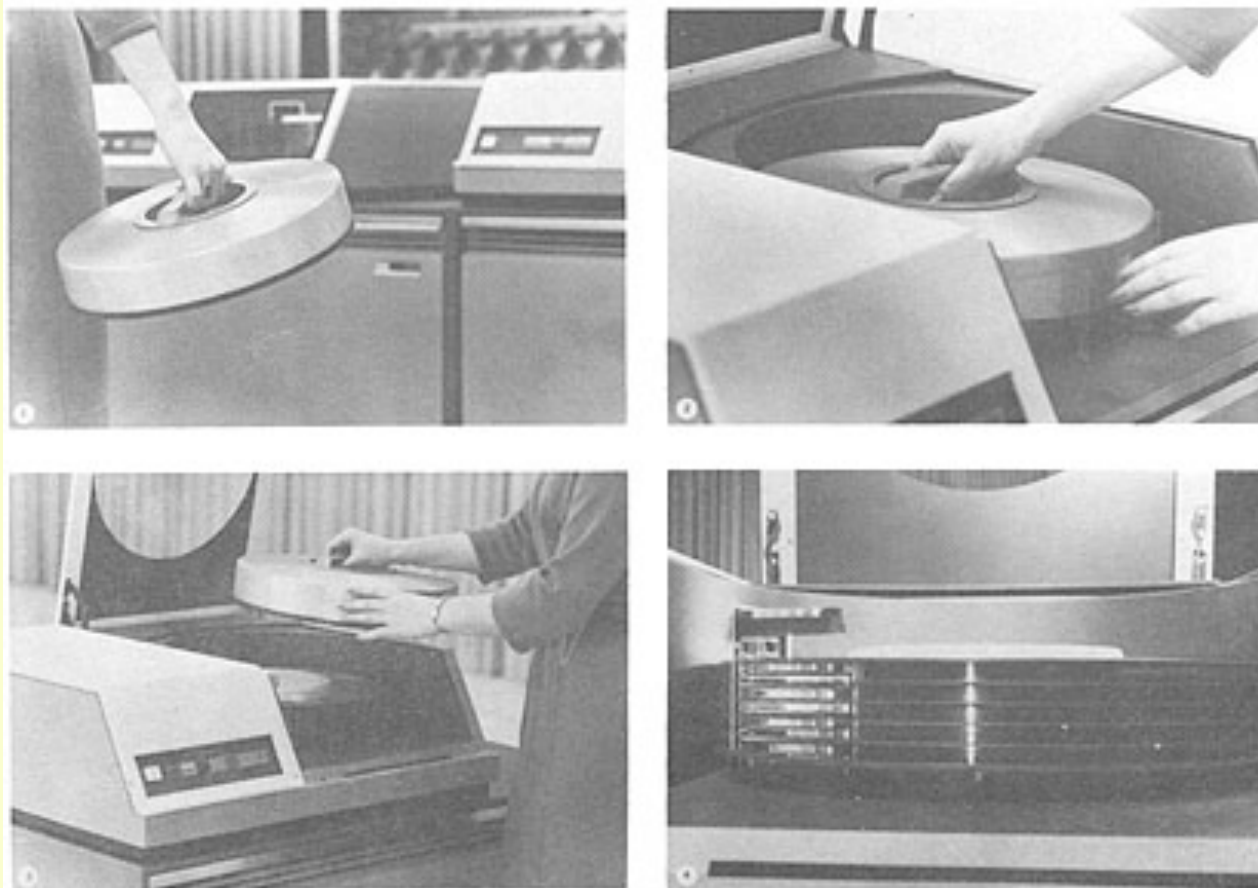

The “S” Curve and changing perceptions with time

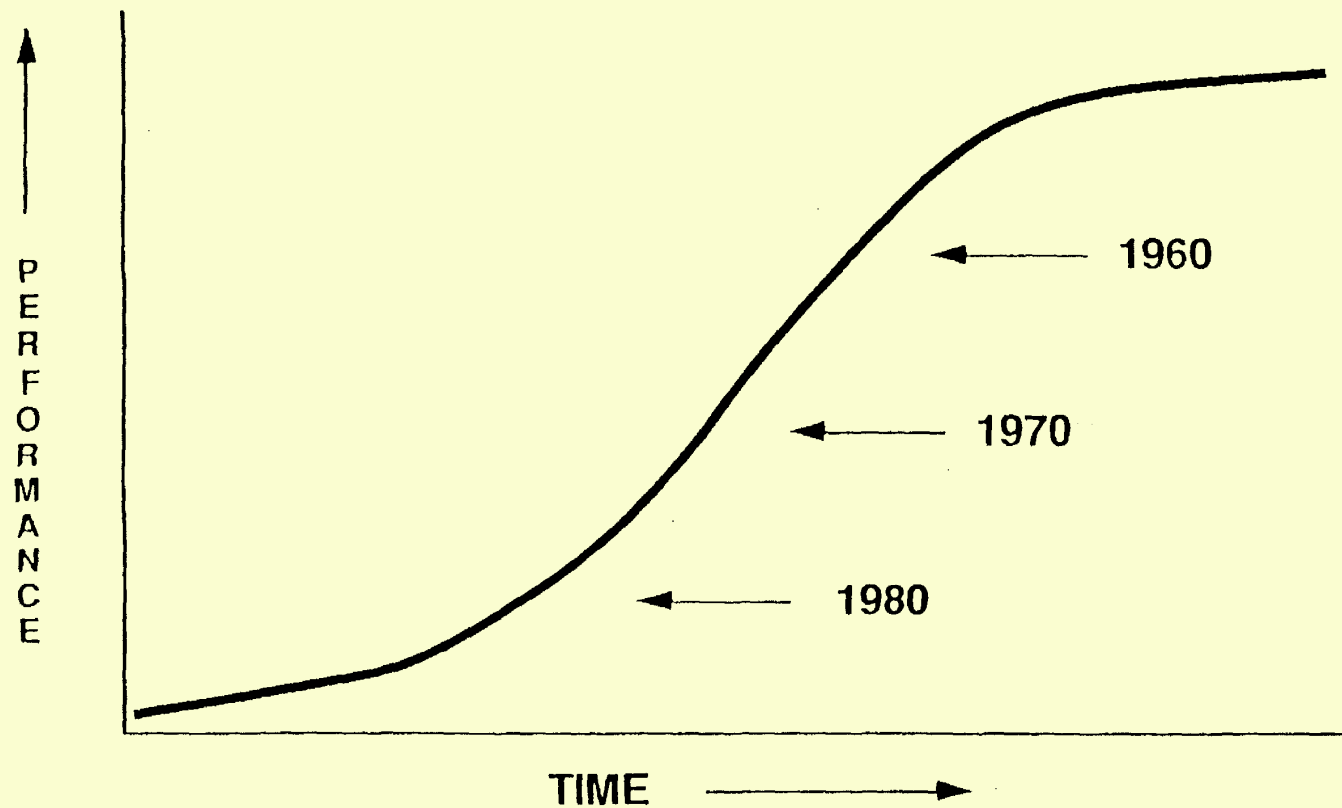

1960 to 1980 (1)

- Sabre Airlines Reservation System, based on IBM 1301, a major business application that led to the pervasive growth of *real time* on-line transaction processing
- Computer industry moves to magnetic disk-based systems
- Disk pack introduced
 - 14 inch disks emerge and become standard. Low cost of 1311 provided path to greatly expand business data processing applications based on transaction processing.
- Beginning of 20 year era of the 14 inch disk (moving back to fixed drives in the late 70's)
- Storage density advances were the key driving factor based on scaling of recording geometry around lower flying heights.
- IBM dominant, drives sold as “integrated” component of systems sales
- Magnetic disk storage beginning to be considered a mature technology

1960 to 1980 (2)

- IBM made product advances primarily by extending existing technology
- Storage research (industry wide) focused on alternative technologies (magneto-optical, holographic, electron beam etc., but in particular magnetic bubbles).
 - Challenge: CAGR magnetic disk density was 36%, or a factor of five every 5 years. Assuming 5 years to bring a new technology into being, an alternative had to be targeted to be at least 5 times beyond the state of the art then existing. Today the situation would be even more challenging

1960 to 1980 (3)

- A few “PCM” companies were successful selling compatible IBM disk drives under the IBM price umbrella
- Diversion of resources to alternative technologies penalized progress. The industry wide conclusion to abandon magnetic bubbles at the end of the 70's led to:
- Universal acceptance that there was no alternative to magnetic recording on the horizon.
- The pool of expertise in magnetic bubble work would be transferred to magnetic disk storage research and development, filling a huge need and bringing about a major increase in research efforts on magnetic disk storage

1980 to 2000 (1)

- PC arrives as consumer product, driving emergence of **small form factor** magnetic disk storage
- New market, without complexities of large systems, allows numerous startup companies, using the existing technology base, to rapidly develop and introduce disk drive products.
- Resulting competition stimulates technical advances and a **disk drive industry** is created.
- As market expands a few computer manufacturers become the major purchasers of disk drives, bringing about a continual pressure for cost reduction to survive.

1980 to 2000 (2)

- Facing world-wide competition an:
- Industry/University Consortium was formed to establish a Industry partnership with academia in the field of data storage through the creation of several university interdisciplinary centers. Several Centers were formed and funded by industry.
- A National Storage Industry Consortium also was formed by industry to jointly seek with universities government support for basic research investigations into data storage.

1980 to 2000 (3)

- Introduction of MR heads leading to thin film heads more sensitive to magnetically recorded fields.
- Scaling driven by a reduction in head to surface spacing also continues to drive linear density (moving down to ½ microinch from 1000 on the RAMAC).
- Based on these two advances a 60% CAGR projected by IBM in 1991.
- This prediction served as self fulfilling prophecy (i.e., became a common industry roadmap) driving dramatic increases in capacity and lower cost/MB
- This projected advance was realized. Later the discovery of the GMR effect lead to much more sensitive read heads and by the end of the nineties the CAGR had increased to 100%

1980 to 2000 (4)

- Disk systems applications stimulate major studies of redundant disks (RAID systems) for reliability and other methods to extend enterprise storage systems applications
- A storage systems industry emerges by using what were now commodity disk products to provide storage systems solutions, an emerging valued added business.
- Disk drive capacity exceeds mass market demand (at existing price points). New applications become essential to sustain industry growth.
- The competitive environment leads to a major consolidation in the disk drive industry

At the Beginning of the 21st century

- Disk diameters now down to one inch
- Storage densities of 100 Gbits/square in achieving a density increase by a factor of 50 million over that of the RAMAC
- The CAGR of storage density is now slowing down
- The “industry” target of a terabit/square inch is now predicated on the transition to **perpendicular recording**; requiring the introduction of new types of head and media
- Disk drive annual volumes are approaching 300 million
- The cost per GB in larger diameters is now about 50 cents.

From SJ Mercury News Interview with Hitachi, Seagate et al

FUTURE HARD DISKS

If the hard drive industry's technology road map is accurate, capacity increases in the next 10 to 20 years will be nothing short of staggering. Here's what could happen to familiar devices.

YEAR	APPLE IPOD MINI PORTABLE MUSIC PLAYER	TYPICAL DESKTOP PERSONAL COMPUTER
2004	4 gigabytes — 1,000 songs, or — 4,000 digital pictures, or — 1 DVD-quality movie	120 gigabytes — 30,000 songs, or — 120,000 digital pictures, or — 30 DVD-quality movies
2010	55 gigabytes — 14,000 songs, or — 55,000 digital pictures, or — 14 DVD-quality movies	1.7 terabytes (1,700 gigabytes) — 425,000 songs, or — 1.7 million digital pictures, or — 425 DVD-quality movies
2020	3 terabytes (3,000 gigabytes) — 764,000 songs, or — 3 million digital pictures, or — 750 DVD-quality movies	86 terabytes (86,000 gigabytes) — 22 million songs, or — 86 million digital pictures, or — 21,500 DVD-quality movies

Songs are assumed to be four minutes each, creating a 4-megabyte file when recorded in MP3 format at 128k bit rate; digital pictures are assumed to be 1 megabyte each, which is typical for today's mid-range digital cameras; DVD-quality movies are assumed to be two hours long, or 4 gigabytes. All figures are approximations.

Source: Mercury News research

Where Storage Density is Headed IBM (1998)

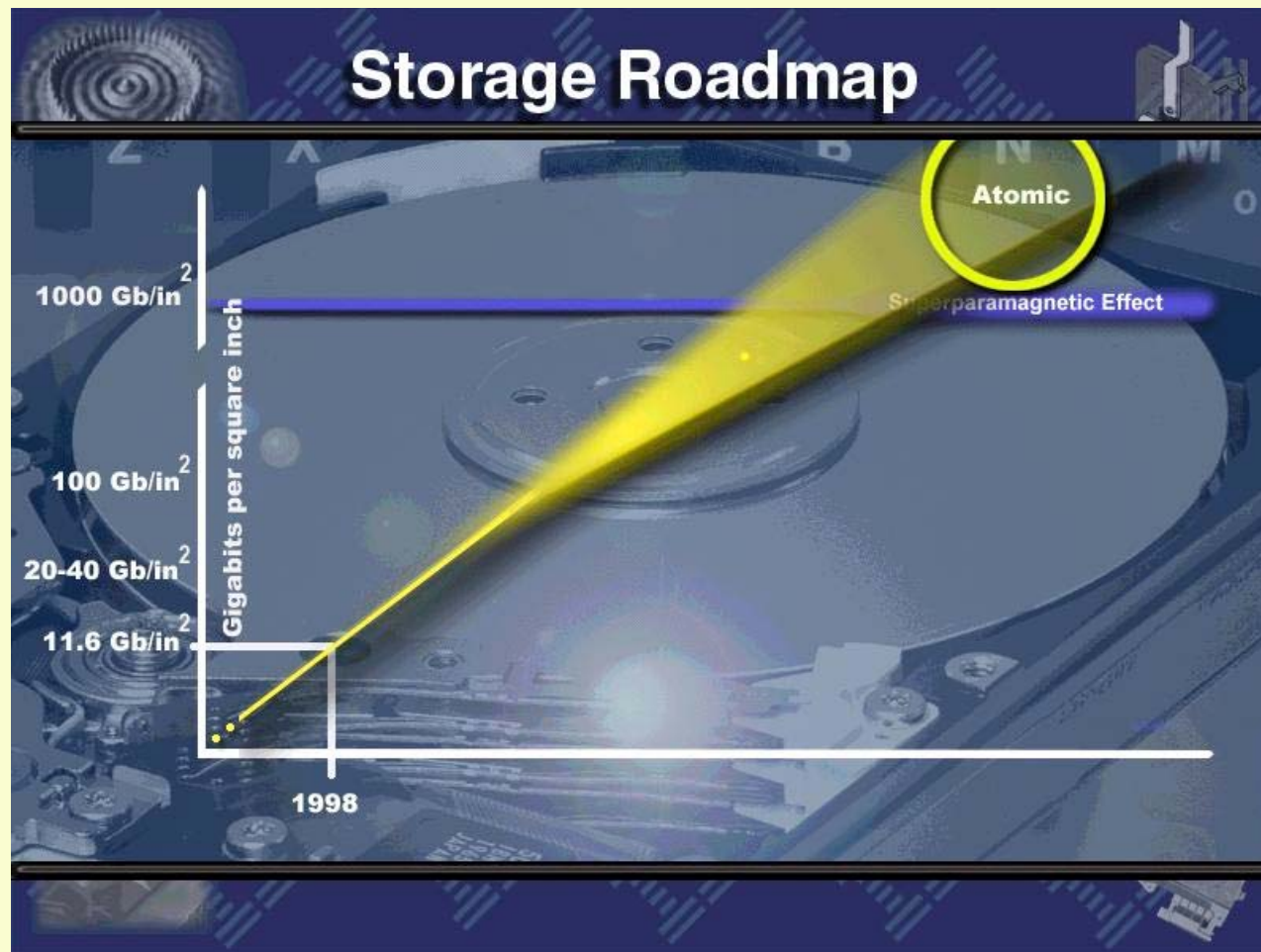

Memory/Storage Hierarchy (still the same after 40 years)

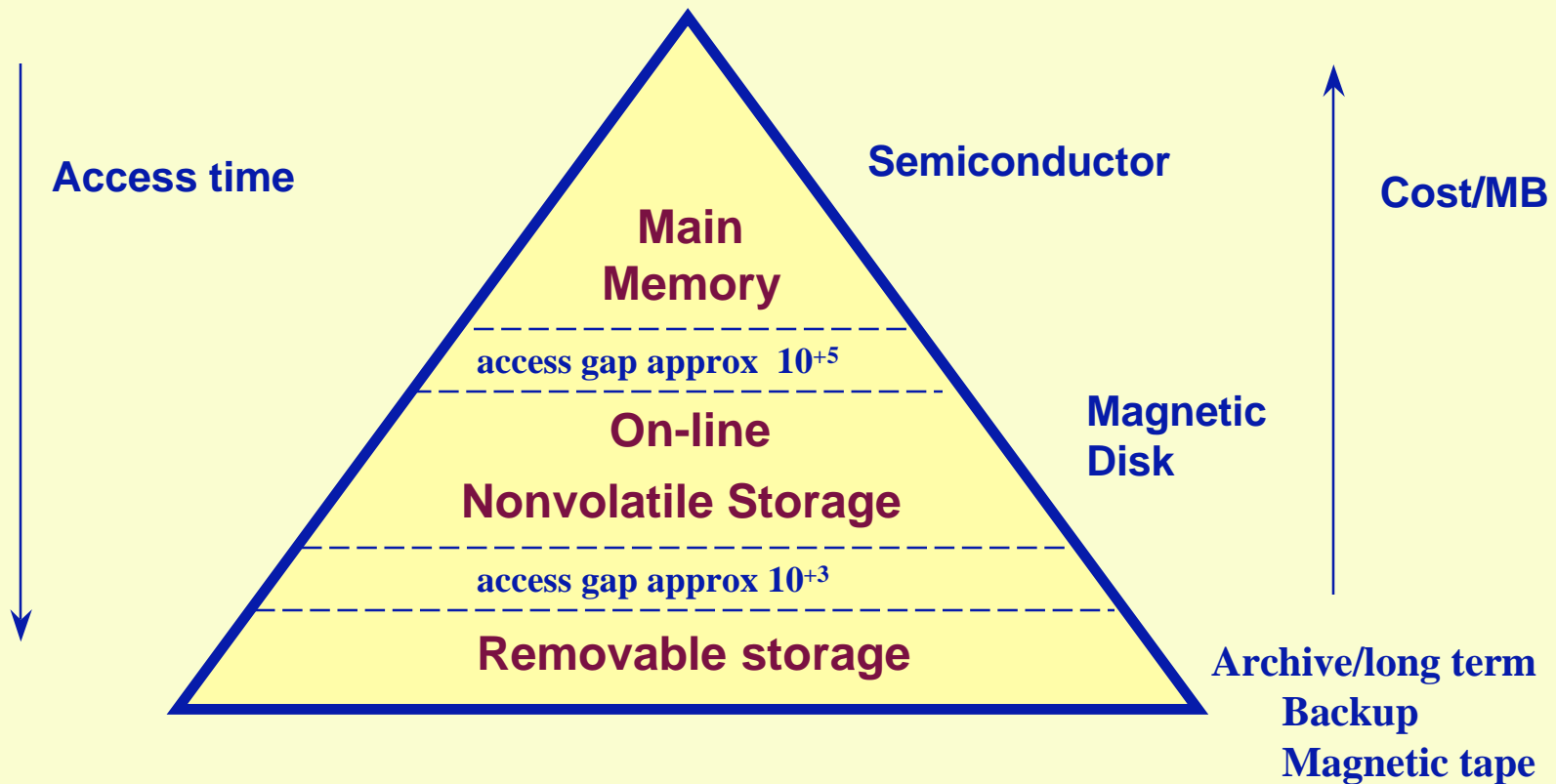

Why Magnetic Disk Storage?

- The base technology has a simplicity and elegance by the use of magnetics (dc motor to spin disks, voice coil for positioning of head, magnetic disk for storage and magnetic heads for reading and writing)
- The technology offers an unequaled set of performance tradeoffs in terms of capacity, access time, data rate and cost/GB
- Magnetic disk storage has dominated on-line real-time storage since its creation and now information storage via the Internet, thus integral part of today's societies.
- The technology is still advancing at a dramatic rate.
- Conclusion: magnetic disk storage will be the major means of information storage for many more decades

MAGNETIC DISK HERITAGE CENTER (MDHC)

Santa Clara University

Mission: Preserve the story and historical legacy of the magnetic disk drive industry

Some Activities of MDHC

- Led the effort and succeeded in making 99 Notre Dame, San Jose, location of the original building that still exists where the RAMAC was created a San Jose City Landmark in 2002.
- Obtained an agreement by the City of San Jose to preserve the building and look to establish a future City of San Jose Technical Museum in the building that will feature magnetic disk storage (2002).
- MDHC created a display, covering the early magnetic disk activities that took place at 99 Notre Dame, and placed it in the building lobby (7 large wall panels) which is available for public viewing. (99 Notre Dame is in downtown San Jose)
- Nominated and succeeded in having the RAMAC system and disk drive made an IEEE Milestone in 2004
- MDHC has received on loan from IBM a RAMAC, the first disk drive, and is currently undertaking to restore this drive to an operational state to place on public display.



Johnson, Reynold B. (1906-1998)

A pioneer in the development of magnetic disk technology and computerized educational systems. He led the development and production of the first random access magnetic disk storage unit and the multiple head actuator.

His effort helped establish San Jose and the Silicon Valley region as the center of the disk drive industry of the world. He holds more than 90 patents.

Awarded National Medal of Technology, 1986

citation:

Introduction and development of magnetic disk storage for computers that provided access to virtually unlimited amounts of information in fractions of a second and is the basis for time sharing systems and storage of millions of records. Over \$10 billion in annual sales and over 100,000 jobs arose from his contributions.

99 Notre Dame, A City Landmark
2002 picture → on 50th anniversary



The original building!

2/28/05

Magnetic Disk Heritage Center

ASH

RAMAC 350 Award (1984)



RAMAC made IEEE Milestone on 4/28/04

IEEE RAMAC MILESTONE CITATION

FIRST COMPUTERS TO USE MAGNETIC DISK STORAGE, 1956

Developed by IBM in San Jose, California at 99 Notre Dame Street from 1952 until 1956, the Random Access Method of Accounting and Control (RAMAC) was the first computer system conceived around a radically new magnetic disk storage device. The extremely large capacity, rapid access, and low cost of magnetic disk storage revolutionized computer architecture, performance, and applications.

RAMAC Restoration Project

Goal: To restore an the original disk drive to an operational state.



RAMAC Restoration Approach

- Restore the original mechanics and mechanisms (including pressurized air head) to their original state.
 - *These aspects represent the key technical innovations!*
- Replace the original vacuum tube and relay control unit with a new controller using current microprocessor technology and servo control techniques. Semiconductor implementations of read/write circuits.
- So far have mechanics working, disk spinning and initial read/write circuitry under design.

RAMAC Restoration Status

- Project regarded as great educational and engineering experience for students
 - Pursued currently through senior design projects, (last academic year and now the current one) each team involving 3 students
 - One part-time student during the summer
- Last year focus was on mechanical access functions, cleaning disks and lubricating spindle motor bearings.
 - Able to at $\frac{1}{4}$ speed move the head-arm assembly to selected disk and track under program control.
- This year the senior design project is focusing on the reading and writing on the disks.
 - Program also will include software to control disk drive over internet
- Expectation that all the functional capabilities will be demonstrated and the “student design” phase will be completed by September 2005.
- Further work will be on packaging, etc., for public display and use.

Disk Drive Mechanics Restored



2/28/05

Magnetic Disk Heritage Center

ASH

Disk Drive and Control Unit



2/28/05

Magnetic Disk Heritage Center

ASH